



DATA SHEET

Navigator

Navigation LED Lights

General information

Navigator wingtip lights are **LED navigation lights** (red & green). Monolith encapsulation ensures that the lamp is **water and vibration resistant**. Lights are much **brighter** comparing to traditional bulb lights. Moreover the required input power for LED lights is lower and does not affect much the overall electric load of your aircraft. The lights are **the most cost effective** model of our product.

Technical Data

Navigation light	YES (red/green)
Strobe light	NO
Operation voltage range	11,8 V - 30 V
Dimensions	95 mm x 40 mm x 27 mm
Weight (2 lamps)	150 g
Operation temperature range	- 35°C to + 60°C
Current - navigation light (2 lamps)	0,4 A
Input power - navigation light (2 lamps)	5,0 W
Navigation light angle	110°
Navigation light luminosity (per lamp)	450 lm
Wiring requirement	0,5 mm ² cable
Encapsulation	Monolith of UV resistant epoxy resin
Reverse polarity protection	YES
Vibration resistance	YES
Water resistance	YES
Warranty	2 years

Drawing

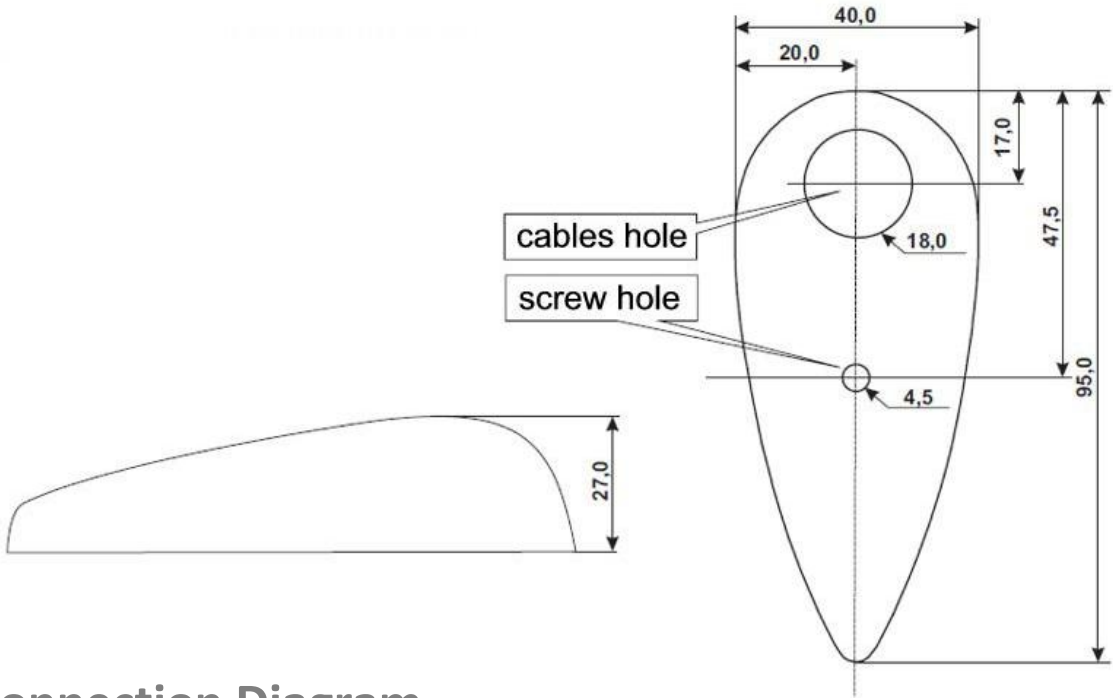

Connection Diagram

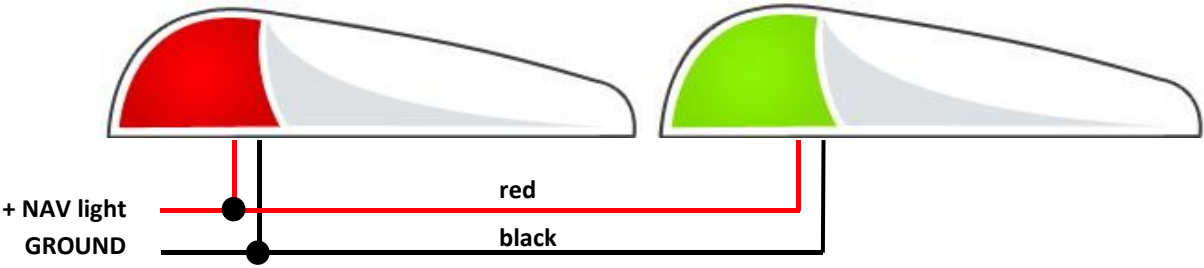

Light Distribution



Wiring Diagram

