



DATA SHEET

Navigator **Ultra**

Navigation/Strobe LED Lights

General information

Navigator Ultra wingtip lights are **LED navigation lights** (red & green) equipped with synchronized **strobe** (white) **light**. Monolith encapsulation ensures that the lamp is **water and vibration resistant**. The lights have **strobe light controller integrated** in the lamp capsule. The installation and connection process is very easy and there is no need for additional external strobe controllers. You simply connect all the wiring directly to the lamp.

Technical Data

Navigation light	YES (red/green)
Strobe light	YES (white)
Voltage range	12 V - 15 V
Dimensions	95 mm x 40 mm x 27 mm
Weight (2 lamps)	170 g
Operation temperature range	- 35°C to + 60°C
Current - navigation light (2 lamps)	0.5 A
Current - strobe light (2 lamps)	3.5 A in peak
Input power - navigation light (2 lamps)	4.0 W
Input power - strobe light (2 lamps)	45 W in peak
Navigation light angle	110°
Navigation light luminosity (per lamp)	450 lm
Strobe light luminosity (per lamp)	2000 lm
Strobe light frequency	120 flashes/min
Wiring requirement	0,5 mm ² cable
Encapsulation	Monolith of UV resistant epoxy resin
Strobe control unit	Lamp built in
Strobe synchronization	YES
Reverse polarity protection	YES
Vibration resistance	YES
Water resistance	YES
Warranty	2 years

Drawing

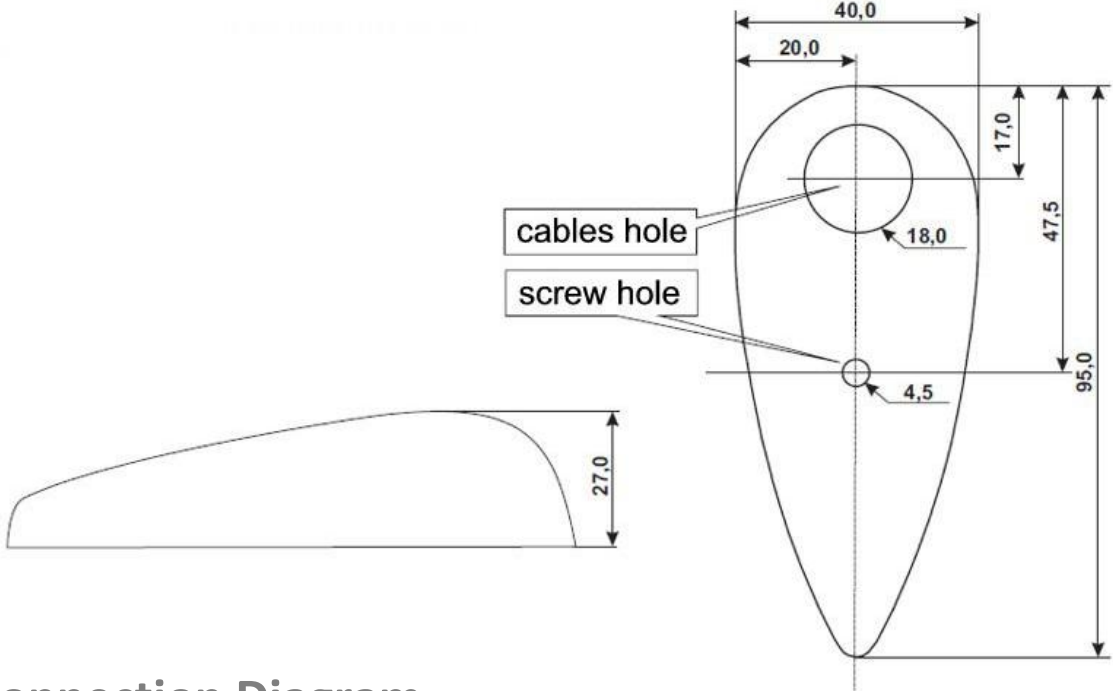

Connection Diagram

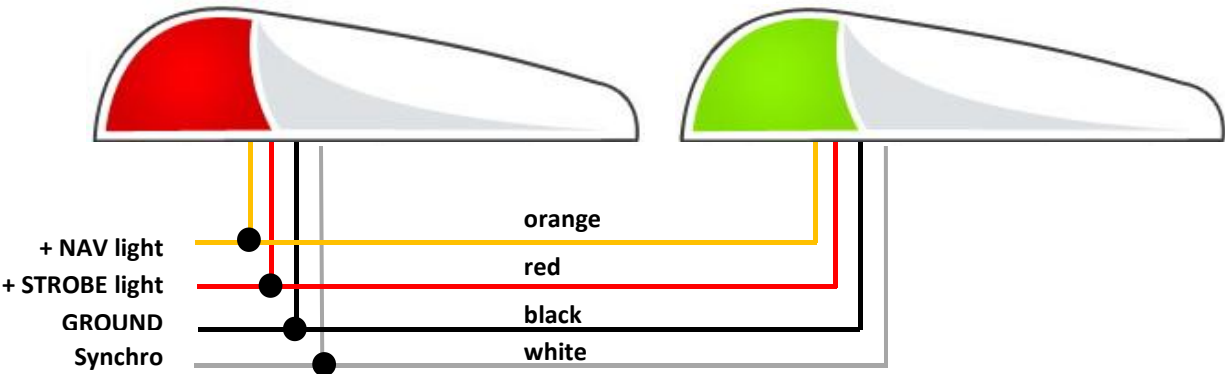

Light Distribution

