

DATA SHEET

Navigator **Ultra** 360

Navigation/Position/Strobe LED Lights

General information

Navigator **Ultra 360** wingtip lights are **LED navigation lights** with integrated **rear position light**, equipped with **strobe light**. They are designed for LSA, Ultralight, KIT and Experimental aircraft.

Navigator **Ultra 360** is all-in-one solution for aircraft lighting which covers all the required light spectrum. The lights are very compact and efficient, always ensuring you to be clearly visible in the air.

All together the set of **Navigator Ultra 360** lights is having **low weight** and **low power consumption** comparing to classic bulb lights.

Technical Data

Navigation light	YES (red/green)
Rear position light	YES (white)
Strobe light	YES (white)
Operation voltage range	11,8 V - 14,8 V
Dimensions	95 mm x 40 mm x 27 mm
Weight (2 lamps)	190 g
Operation temperature range	- 35°C to + 60°C
Current - navigation light (2 lamps)	0,5 A
Current - strobe light (2 lamps)	2,8 A in peak
Input power - navigation light (2 lamps)	6,0 W
Input power - strobe light (2 lamps)	29 W in peak
Navigation light angle	110°
Rear position light angle	140°
Nav/Pos light luminosity (per lamp)	600 lm
Strobe light luminosity (per lamp)	1000 lm
Strobe light frequency	120 flashes/min
Wiring requirement	0,5 mm ² cable
Encapsulation	Monolith of UV resistant epoxy resin
Strobe control unit	Lamp built in
Reverse polarity protection	YES
Vibration resistance	YES
Water resistance	YES
Warranty	2 years

Drawing

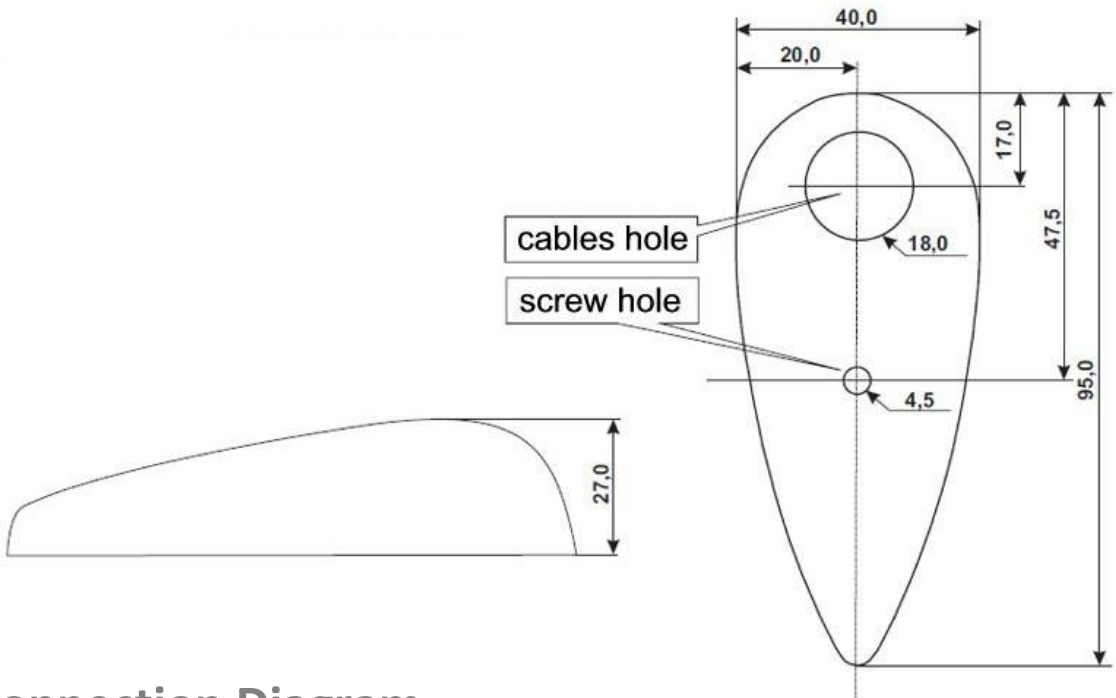

Connection Diagram

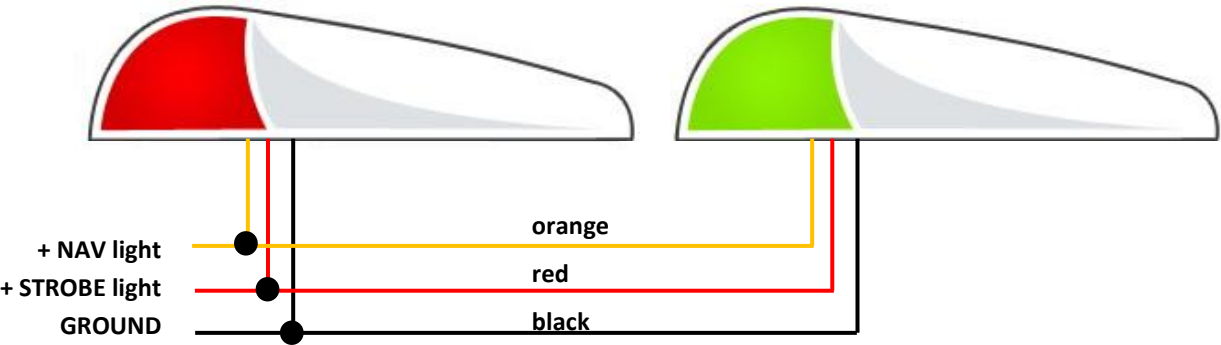

Light Distribution

